

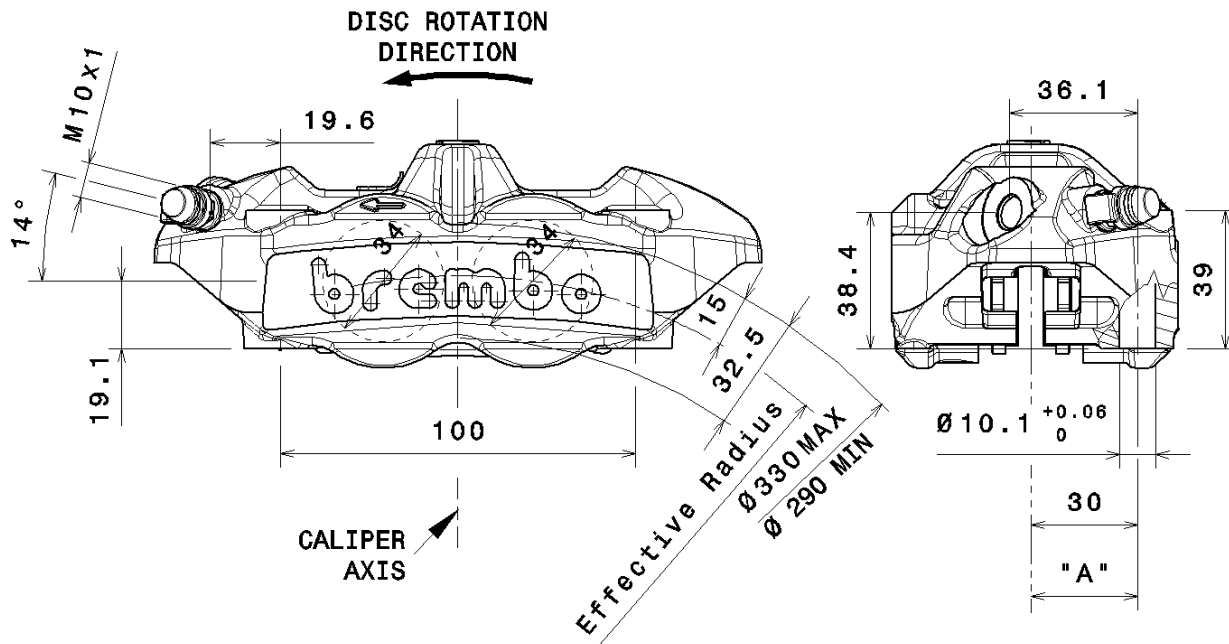

FIXED CALIPER

M4.34 a
20.9885.30
20.9885.40



DESCRIPTION

Fixed caliper with 4 opposed pistons, made in a single body.
 Construction material: Aluminium Alloy.
 Operating fluid: brake fluid DOT4.
 N.B: Drawing shows left side caliper.
 Code 20.9885.30.
 Code 20.9885.40 specular.
 Mounting side behind the fork.

PADS SHAPE AND DIMENSIONS

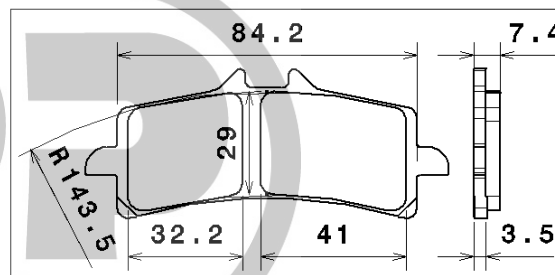

TECHNICAL CHARACTERISTICS

Pistons number and diameter:	4 34 mm	Average pad surface (1 pad):	21.0 cm ²
MAX working pressure:	70 bar	Mass (with sintered pad):	1.015 Kg
"A" Disc position (TOLERANCE):			
Disc thickness 5.0 mm:	±0.8 mm		
Disc thickness 4.5 mm:	±0.8 mm		

CONFIGURATION

CHARACT CODE CALIPER	PADS FRICTION MATERIAL	BODY COLOUR	MOUNTING SIDE	USABLE DISCS THICKNESS	BRAKE FLUID FOR PADS WEAR
20.9885.30 20.9885.40	TOSHIBA TT 2910 HH	GREY TITANIUM	SX DX	5.0 mm 4.5 mm	14.0 cm ³

AVAILABLE SPARE PARTS

SPARE PARTS CODE CALIPER	PADS	BLEEDER SCREW	20 BOOTS	SPRING
20.9885.30 20.9885.40	107.9882.10	105.3387.52	105.1502.20	120.2255.79