

	<h1>FIXED CALIPER</h1>	<b>P 32 F</b>	
		<b>20.5161.16</b>	<b>A</b>

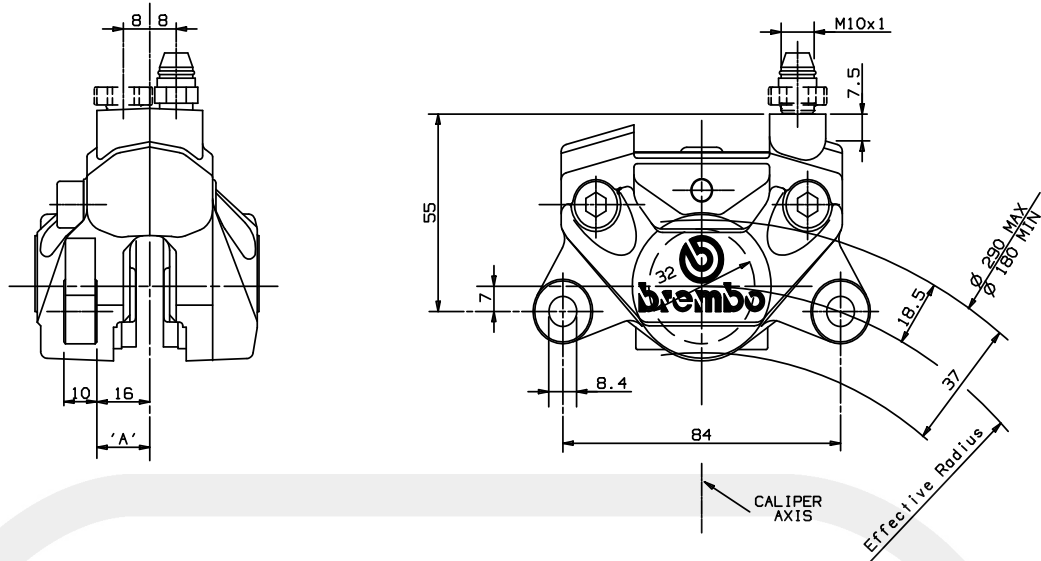

### DESCRIPTION

Fixed caliper with 2 opposed pistons, realized by semicalipers joined by bolts. Pads are supported by one pin. Construction Material: Aluminium Alloy. Operating fluid: brake fluid DOT4.

### PADS SHAPE AND DIMENSIONS

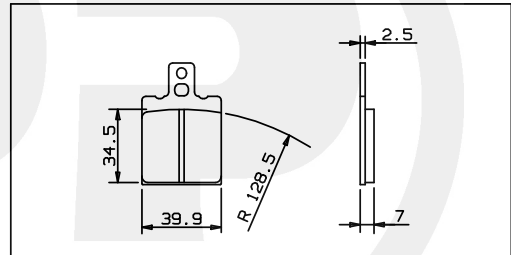

### TECHNICAL CHARACTERISTICS

Pistons number and diameter:	2	32mm	Average pad surface (1 pad):	12.5 cm <sup>2</sup>
MAX working pressure:		100bar	Weight (with not sintered pad):	0.540 Kg
A) Disc position (TOLERANCE):				
	Disc thickness 6.4 mm	±0.3 mm		
	Disc thickness 6.0 mm	±0.3 mm		

### CONFIGURATION

CHARACT. CODE CALIPER	PADS FRICTION MATERIAL	BODY COLOR	MOUNT. SIDE	USABLE DISCS THICKNESS	BRAKE FLUID FOR PADS WEAR
20.5161.16	FERIT I/D 450 FF	GOLD	SX DX	6.4 mm 6.0 mm	6.10 cm <sup>3</sup>

### AVAILABLE SPARE PARTS

SPARE PARTS CODE CALIPER	PADS	BLEEDER SCREW	DUST COVER	PIN
20.5161.16	107.2686.25	105.3246.11	205.1502.10	120.2800.11

Indicating informations subject to modification. For further specifications contact Technical Section.

LAST UPDATE: 09/03/1995