

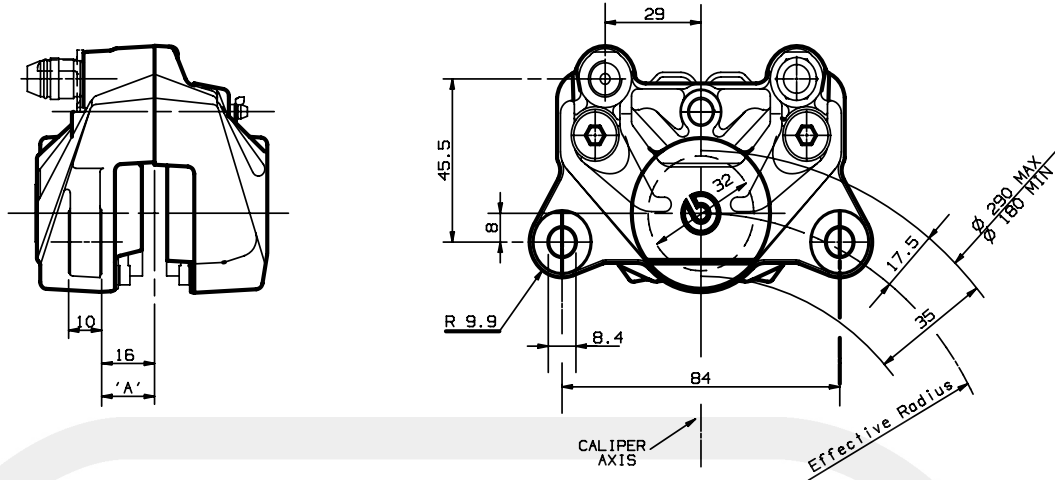

FIXED CALIPER

P 32 G

**20.6950.12
 22 C**



DESCRIPTION

Fixed caliper with 2 opposed pistons, realized by semicalipers joined by bolts. Pads are supported by one pin. Construction Material: Aluminium Alloy. Operating fluid: brake fluid DOT4.

N.B.: drawing shows caliper Code 20.6950.12
 Caliper Code 20.6950.22 specular.

PADS SHAPE AND DIMENSIONS

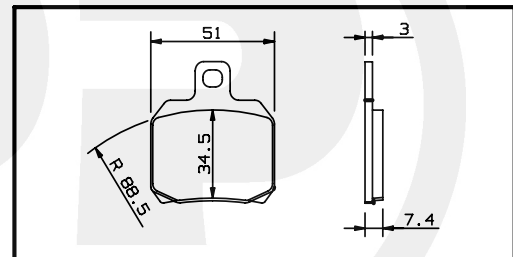

TECHNICAL CHARACTERISTICS

Pistons number and diameter:	2 32mm	Average pad surface (1 pad):	16.1 cm ²
MAX working pressure:	70bar	Weight (with sintered pads):	0.600 Kg
A) Disc position (TOLERANCE):	±0.6 mm		

CONFIGURATION

CHARACT. CODE CALIPER	PADS FRICTION MATERIAL	BODY COLOR	MOUNT. SIDE	USABLE DISCS THICKNESS	BRAKE FLUID FOR PADS WEAR
20.6950.12 22	TT H38 GF (TOSHIBA)	BLACK	SX DX	5.0 mm	6.6 cm ³

AVAILABLE SPARE PARTS

SPARE PARTS CODE CALIPER	PADS	BLEEDER SCREW	DUST COVER	PIN SPLIT SPRING
20.6950.12 22	107.6949.12	105.3387.10	105.1502.10	120.5116.11

Indicating informations subject to modification.
 For further specifications contact Technical Section.

LAST UPDATE: 09/02/1999