

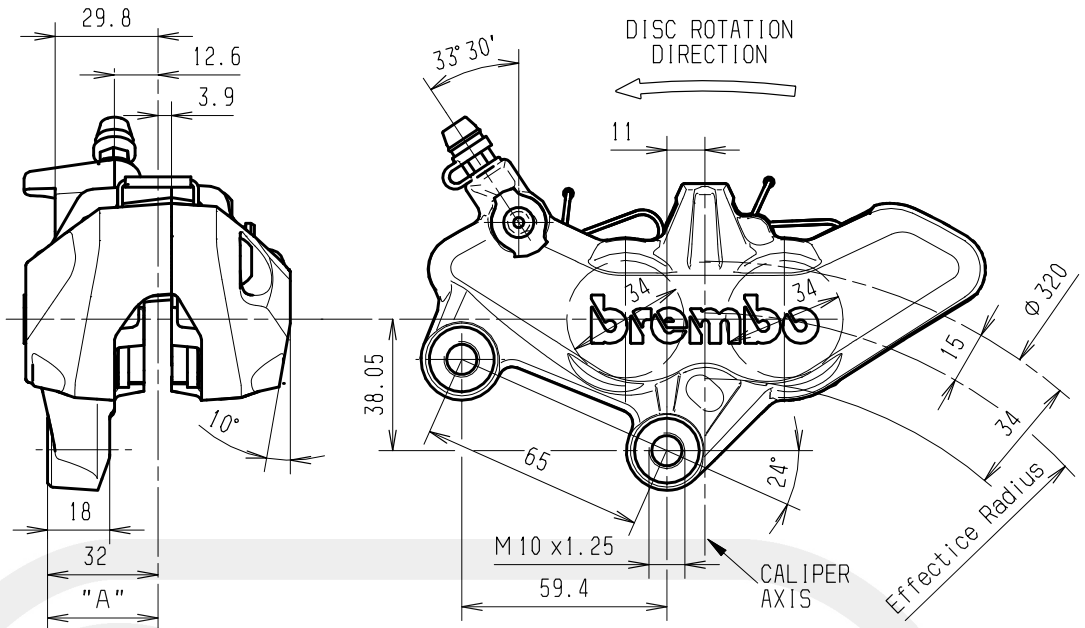

FIXED CALIPER

P4.34 a

20.7850.12



DESCRIPTION

Fixed caliper with 4 opposed pistons, realized by semicalipers joined by bolts.
Construction Material: Aluminium Alloy.
Operating fluid: brake fluid DOT4.
N.B.: Drawing shows left side caliper.
Code 20.7850.12.
Mounting side behind the fork.

PADS SHAPE AND DIMENSIONS

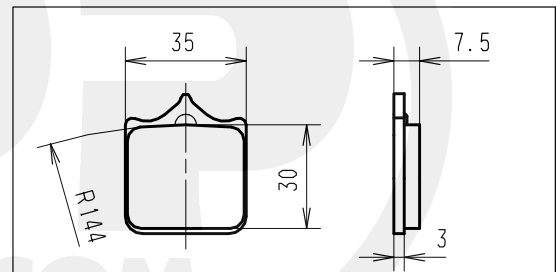

TECHNICAL CHARACTERISTICS

Pistons number and diameter:	4 34 mm	Average pad surface (1 pad):	9.90 cm ²
MAX working pressure:	70 bar	Weight (with sintered pad):	0.971 kg
"A" Disc position (TOLERANCE):			
Disc thickness 5.0 mm	±0.8 mm		
Disc thickness 4.5 mm	±0.8 mm		

CONFIGURATION

CHARACT. CODE CALIPER	PADS FRICTION MATERIAL	BODY COLOR	MOUNT. SIDE	USABLE DISCS THICKNESS	BRAKE FLUID FOR PADS WEAR
20.7850.12	TOSHIBA TT 2802 GG	GOLD	SX	5.0 mm 4.5 mm	14.2 cm ³

AVAILABLE SPARE PARTS

SPARE PARTS CODE CALIPER	PADS	BLEEDER SCREW	DUST COVER	SPRING PIN
20.7850.12	107.7855.11	105.3387.52	105.1502.20	122.4849.56

Indicating informations subject to modification.
For further specifications contact Technical Section.

LAST UPDATE: 07/05/2003