

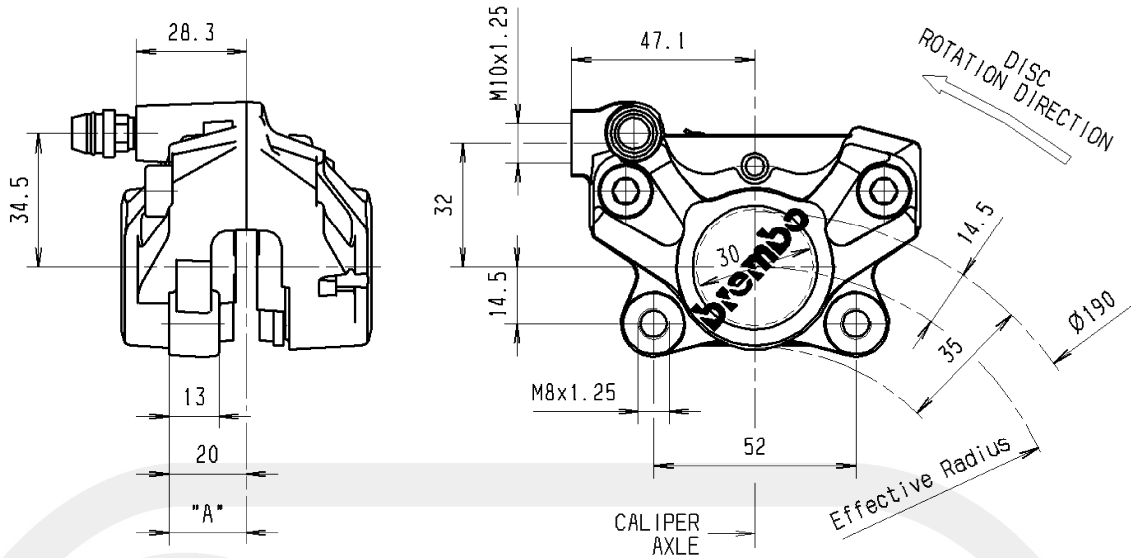

# FIXED CALIPER

P 30 b  
20.9860.11



## DESCRIPTION

Fixed caliper with 2 opposed pistons, realized by semicalipers joined by bolts. Pads are supported by one pin. Construction Material: Aluminium Alloy. Operating fluid: brake fluid DDT4.

## PADS SHAPE AND DIMENSIONS

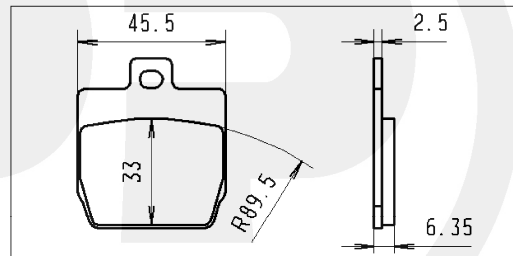

## TECHNICAL CHARACTERISTICS

Pistons number and diameter:	2	30 mm	Average pad surface (1 pad):	13.6 cm <sup>2</sup>
MAX working pressure:		70 bar	Weight (with not sintered pad):	0.490 kg
"A" Disc position (TOLERANCE):		±0.5 mm		

## CONF IGURATION

CHARACT. CODE CALIPER	PADS FRICTION MATERIAL	BODY COLOR	MOUNT. SIDE	USABLE DISCS THICKNESS	BRAKE FLUID FOR PADS WEAR
20.9860.11	FERIT 4424	GOLD	SX	3.5 mm	5.5 cm <sup>3</sup>

## AVAILABLE SPARE PARTS

SPARE PARTS CODE CALIPER	PADS	BLEEDER SCREW	DUST COVER	PIN PAD SPRING CLIP
20.9860.11	107.6966.11	105.3246.14	105.1502.10	120.2800.65

Indicating informations subject to modification.  
For further specifications contact Technical Section.

LAST UPDATE: 29/07/2005