

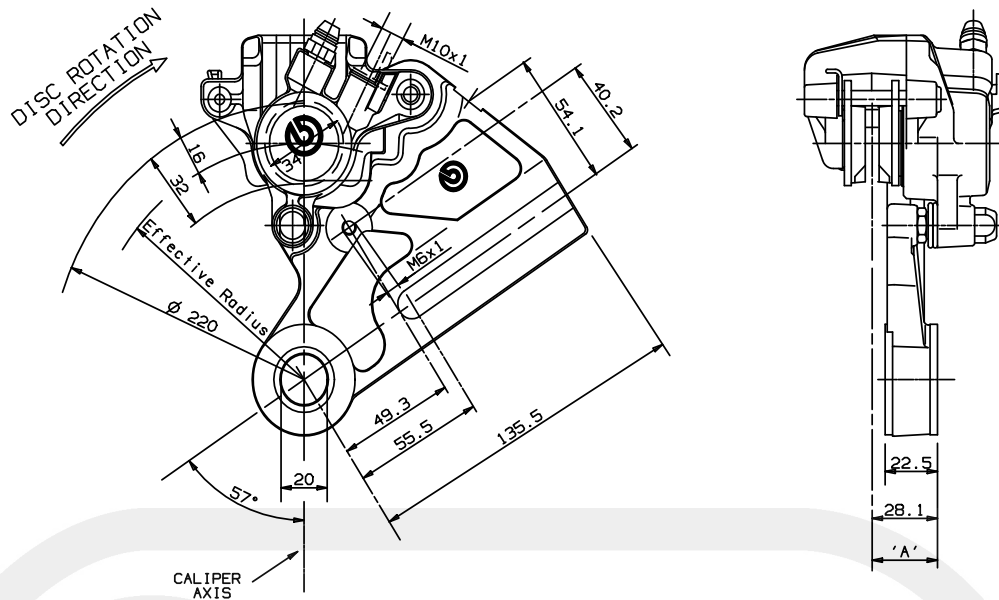

## FLOATING CALIPER

**PF 34 B**  
**22.5550.61**



### DESCRIPTION

Floating caliper with 1 piston.  
 Caliper's body slides on one bracket.  
 Pads are supported by one pin and one bracket.  
 Construction Material: Aluminium Alloy.  
 Operating fluid: brake fluid DOT4.

N.B.: drawing shows right side caliper.

### PADS SHAPE AND DIMENSIONS

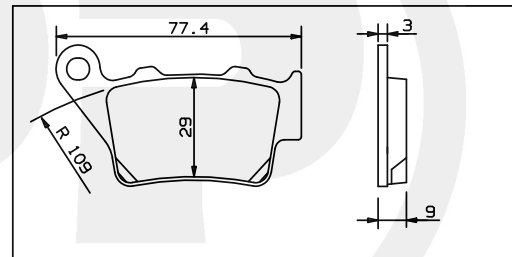

### TECHNICAL CHARACTERISTICS

Pistons number and diameter:	1 34mm	Average pad surface (1 pad):	14.6 cm <sup>2</sup>
MAX working pressure:	70bar	Weight (with not sintered pads):	0.985 Kg
A) Disc position (TOLERANCE):	±0.26 mm		
Usable disc diameter:	220 mm		

### CONFIGURATION

CODE CALIPER	CHARACT.	PADS FRICTION MATERIAL	BODY COLOR	BRACKET COLOR	MOUNT. SIDE	USABLE DISCS THICKNESS	BRAKE FLUID FOR PADS WEAR
22.5550.61		FERIT I/D 450 FF	NATURAL	NATURAL	DX	5.0 mm	10.26 cm <sup>3</sup>

### AVAILABLE SPARE PARTS

CODE CALIPER	SPARE PARTS	PADS	BLEEDER SCREW	DUST COVER	BOOTS	PIN/RETAINER	SPRING/STEEL CLIP
22.5550.61		107.5552.10	105.3246.11	105.1502.10	122.4746.14	122.5089.22	120.4683.22

Indicating informations subject to modification.  
 For further specifications contact Technical Section.

LAST UPDATE: 26/02/1997