

	<h1>FLOATING CALIPER</h1>	PF 2x28 D	
		22.5930.30 .40	A

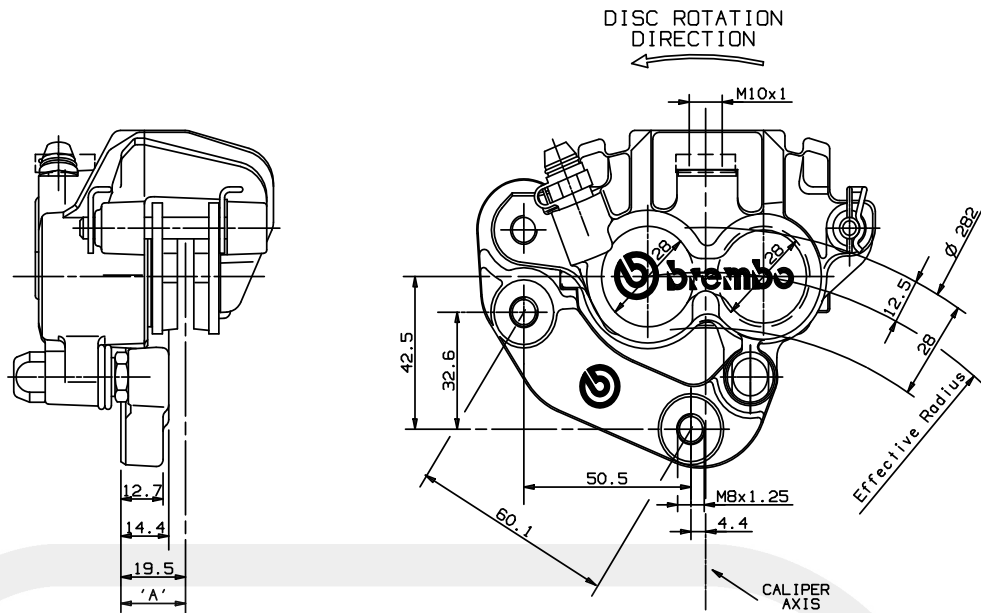

DESCRIPTION

Floating caliper with 2 pistons.
Caliper's body slides on one bracket.
Pads are supported by one pin and one bracket.
Construction Material: Aluminium Alloy.
Operating fluid: brake fluid DOT4.
N.B.: drawing shows left side caliper.
Code 22.5930.30
Code 22.5930.40 specular.
Mounting side behind the fork.

PADS SHAPE AND DIMENSIONS

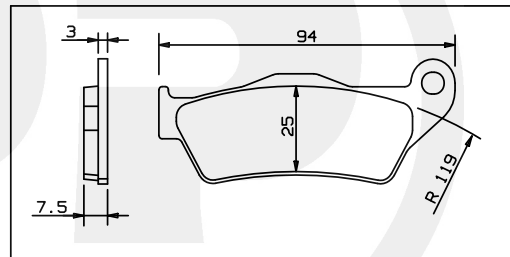

TECHNICAL CHARACTERISTICS

Pistons number and diameter:	2 28mm	Average pad surface (1 pad):	16.9 cm ²
MAX working pressure:	70bar	Weight (with not sintered pads):	0.745 Kg
A) Disc position (TOLERANCE):	±0.5 mm		
Usable disc diameter:	282 mm		

CONFIGURATION

CODE CALIPER	CHARACT.	PADS FRICTION MATERIAL	BODY COLOR	BRACKET COLOR	MOUNT. SIDE	USABLE DISCS THICKNESS	BRAKE FLUID FOR PADS WEAR
22.5930.30 .40		TEXTAR T416	GOLD	NATURAL	SX DX	5.0 mm	10.35 cm ³

AVAILABLE SPARE PARTS

CODE CALIPER	SPARE PARTS	PADS	BLEEDER SCREW	DUST COVER	BOOTS	PIN/RETAINER	SPRING/STEEL CLIP
22.5930.30 .40		107.5269.20	105.3387.60	105.1502.20	122.4746.14	122.5089.21	120.4683.30

Indicating informations subject to modification.
For further specifications contact Technical Section.

LAST UPDATE: 30/05/1996