

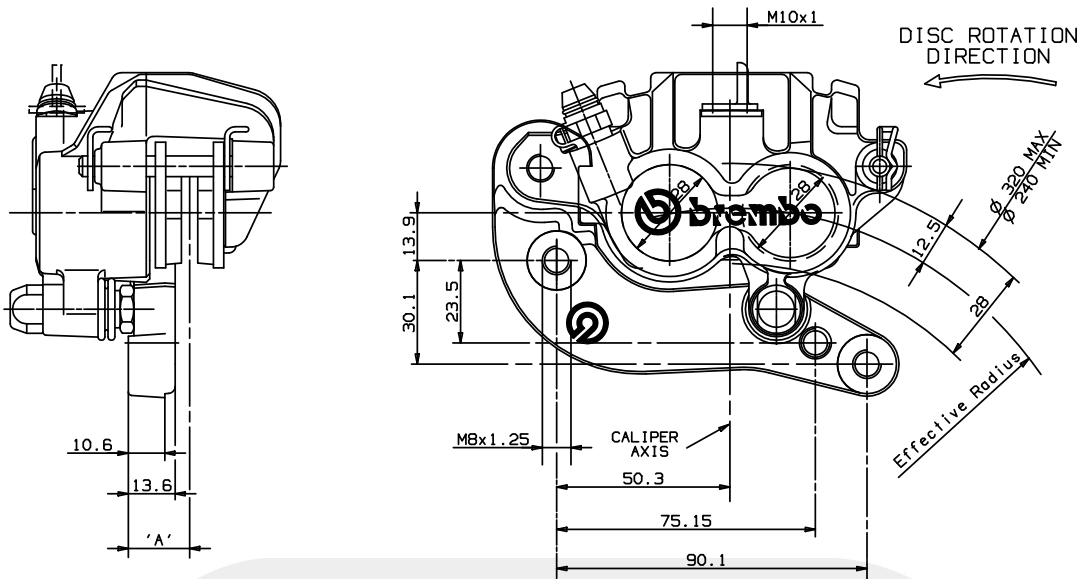

# FLOATING CALIPER

**PF 2x28 D**

**22.5930.62**



## DESCRIPTION

Floating caliper with 2 pistons.  
Caliper's body slides on one bracket.  
Pads are supported by one pin and one bracket.  
Construction Material: Aluminium Alloy.  
Operating fluid: brake fluid DOT4.

N.B.: drawing shows left side caliper.  
Mounting side behind the fork.

## PADS SHAPE AND DIMENSIONS

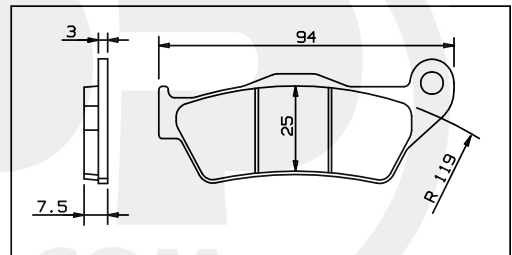

## TECHNICAL CHARACTERISTICS

Pistons number and diameter:	2 28mm	Average pad surface (1 pad):	16.9 cm <sup>2</sup>
MAX working pressure:	70bar	Weight (with sintered pads):	0.767 Kg
A) Disc position (TOLERANCE):	±0.4 mm		
disc thickness 3.5mm :	17.95mm		
disc thickness 4.0mm :	17.70mm		
Usable disc diameter:	240/320 mm		

## CONFIGURATION

CHARACT. CODE CALIPER	PADS FRICTION MATERIAL	BODY COLOR	BRACKET COLOR	MOUNT. SIDE	USABLE DISCS THICKNESS	BRAKE FLUID FOR PADS WEAR
22.5930.62	TT 2701 HH	NATURAL	NATURAL	SX	3.5 mm 4.0 mm	12.1 cm <sup>3</sup>

## AVAILABLE SPARE PARTS

SPARE PARTS CODE CALIPER	PADS	BLEEDER SCREW	DUST COVER	BOOTS	PIN/RETAINER	SPRING/STEEL CLIP
22.5930.62	107.5269.15	105.3387.60	105.1502.20	122.4746.14	122.5089.21	120.4683.20

Indicating informations subject to modification.  
For further specifications contact Technical Section.

LAST UPDATE: 04/02/1999